

Dimensions

1. Indoor Unit

1.1 CS-RU9AKQ / CS-RU12AKQ / CS-RU18AKQ

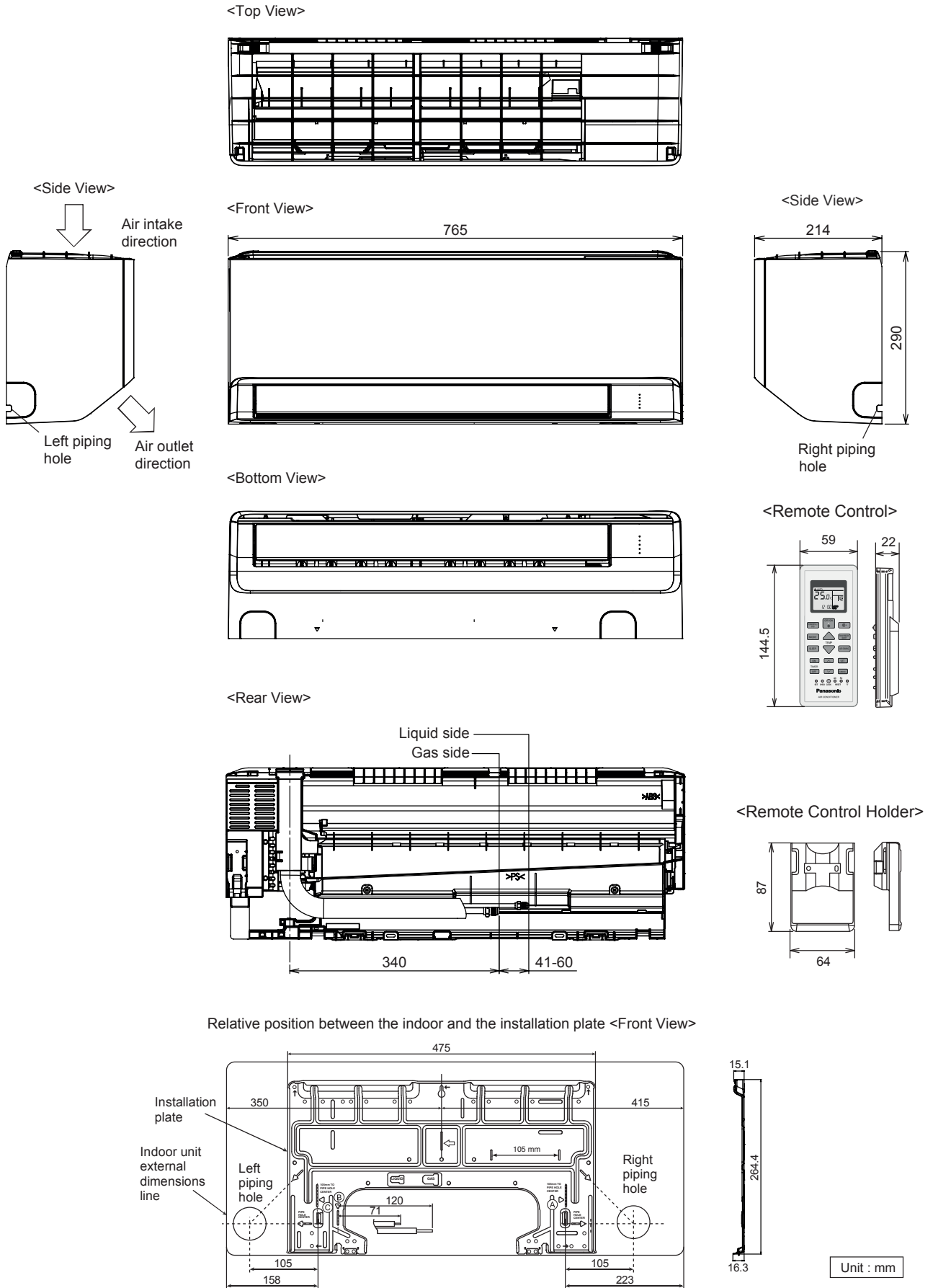

2. Outdoor Unit

2.1 CU-RU9AKQ

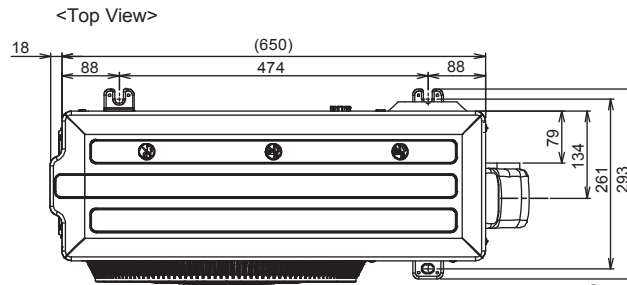
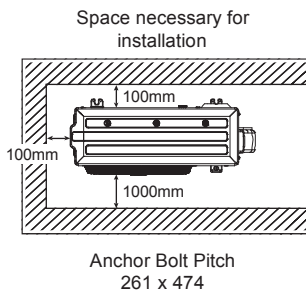

2-way valve at Liquid side
(High Pressure)
3-way valve at Gas side
(Low Pressure)

<Side View>

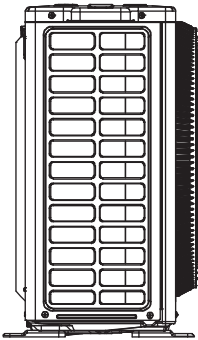

<Front View>

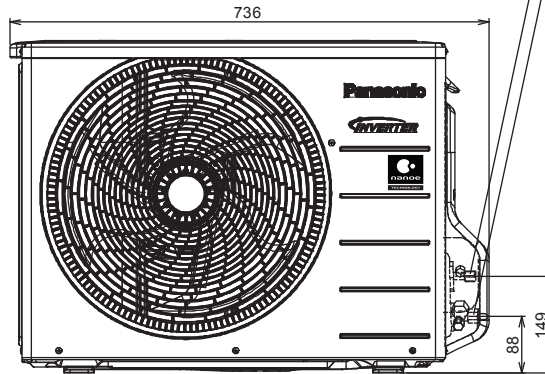

<Side View>

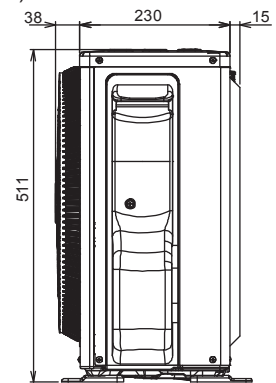

Unit : mm

2.2 CU-RU12AKQ

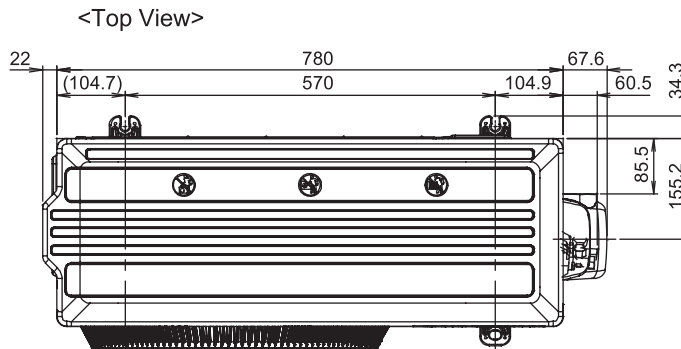
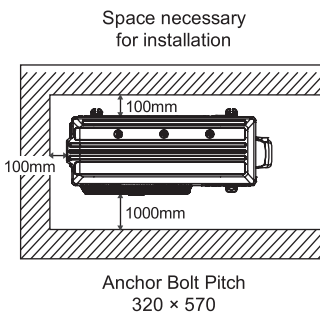

2-way valve at
Liquid side
(High Pressure)

<Side View>

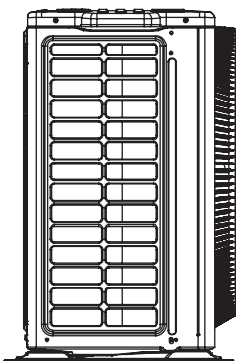

<Front View>

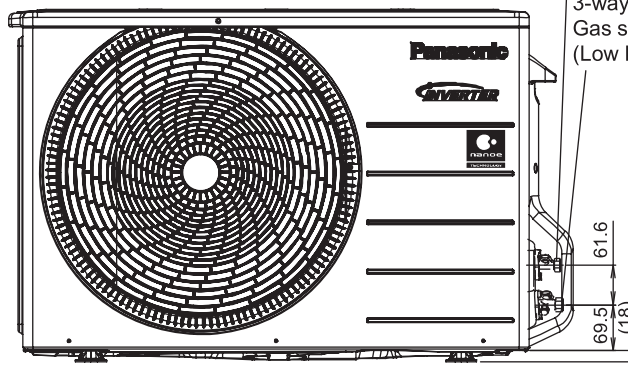

3-way valve at
Gas side
(Low Pressure)

<Side View>

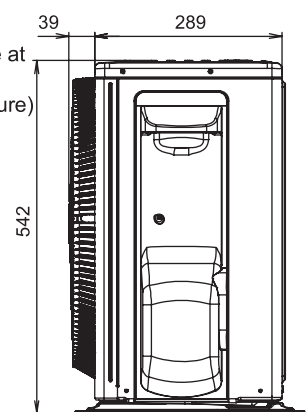

Unit: mm

2.3 CU-RU18AKQ

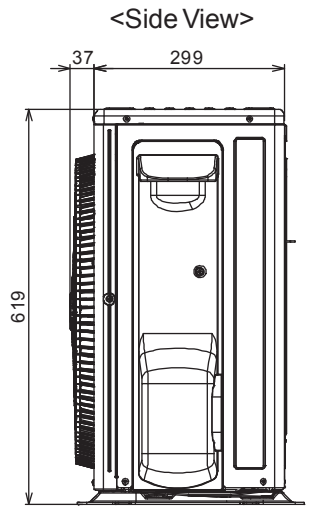
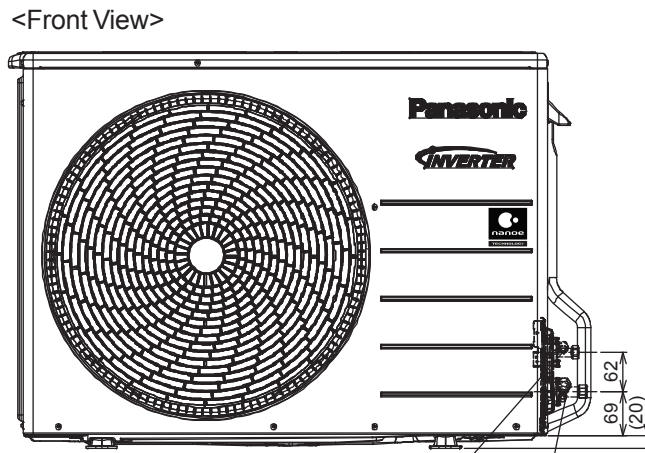
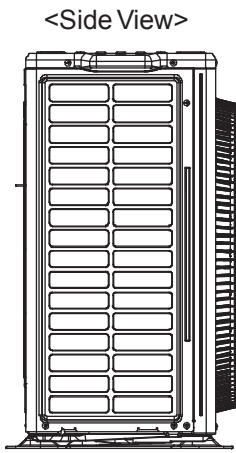
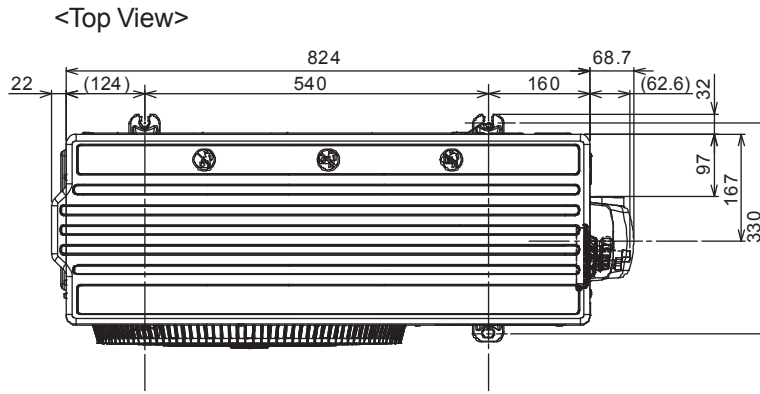
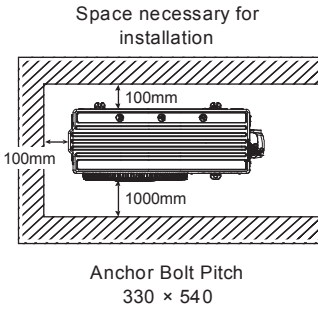

Unit : mm

3-way valve at Gas side
(Low Pressure)
2-way valve at Liquid side
(High Pressure)